

# 400G-FR4-3-Open Eye Technical Specification

**Rev 2.0 February 18, 2022**

**Chair** – Marek Tlalka, Macom

**Editors** –Tom Palkert, Macom, Mark Kimber, Semtech  
Dan Draper, Macom, Ed Frlan, Semtech

## Revisions

Rev	Date	Description
1.0	31 Jan 2022	First release to MSA
2.0	18 Feb 2022	First Public Release

## CONTENTS

CONTENTS.....	2
TABLES.....	4
FIGURES.....	4
1 References and Conventions .....	5
1.1 Industry Documents.....	5
1.2 Sources .....	5
1.3 Conventions.....	5
2 Keywords, Acronyms, and Definitions.....	6
2.1 Keywords.....	6
2.2 Acronyms and Abbreviations .....	6
2.3 Definitions .....	7
3 GENERAL .....	9
3.1 Scope .....	9
3.2 400G-FR4-3 Open Eye Module Block Diagram.....	9
3.3 Functional Description .....	9
3.4 Hardware Signaling Pins.....	10
3.5 Module Management Interface.....	10
3.6 FEC Requirements .....	10
3.7 High Speed Electrical Characteristics .....	10
3.8 Mechanical Dimensions .....	10
4 400G-FR4-3-OPEN EYE OPTICAL SPECIFICATIONS .....	10
4.1 Optical Specifications .....	10
4.1.1 400G-FR4-3-Open Eye transmitter optical specifications .....	11
4.1.2 400G-FR4-3-Open Eye receive optical specifications .....	12
4.1.3 400G-FR4-3-Open Eye illustrative link power budget .....	13
5 DEFINITION OF OPTICAL PARAMETERS AND MEASUREMENT METHODS .....	14
5.1 Test Patterns for Optical Parameters.....	14
5.2 Inter-Eye Skew.....	14
5.3 Skew Variation.....	14
5.4 Wavelength .....	15
5.5 Average Optical Power ( $P_{av}$ ).....	15
5.6 P3 Level .....	15
5.7 P0 Level .....	15

# 400G-FR4-3 Technical Specifications Rev 2.0

5.8	Optical Modulation Amplitude ( $OMA_{outer}$ )	16
5.9	Transmitter optical power (peak-peak)	16
5.10	Lower Threshold	16
5.11	Middle Threshold	16
5.12	Upper Threshold	17
5.13	$UI_{mid}$	17
5.14	Middle Eye Center	17
5.15	Lower Eye Center	17
5.16	Upper Eye Center	17
5.17	$P_{3\_mean}$ , $P_{2\_mean}$ , $P_{1\_mean}$ , $P_{0\_mean}$	18
5.18	DC Balance	18
5.19	Symbol Level Symmetry	18
5.20	$EH_{low}$ , $EH_{mid}$ , $EH_{upp}$	18
5.21	$EW_{low}$ , $EW_{mid}$ , $EW_{upp}$	18
5.22	Transmitter Eye and VEC Measurements	18
5.22.1	Transmitter Test 1: Short pattern deterministic test	19
5.22.2	Transmitter Test 2: Long pattern statistical test	20
5.23	Extinction Ratio	25
5.24	Relative Intensity Noise ( $RIN_{17.1OMA}$ )	25
5.25	Reference Receiver	25
5.26	Receiver Sensitivity	25
5.27	Stressed receiver sensitivity	26
5.27.1	Stressed receiver conformance test block diagram	26
5.27.2	Stress receiver conformance test signal characteristics	27
5.27.3	Stressed receiver conformance test signal verification	28
5.27.4	Sinusoidal jitter stressor for the receiver conformance test	29
6	FIBER OPTIC CABLING MODEL	30
7	CHARACTERISTICS OF THE FIBER OPTIC CABLING	31
7.1	Optical Fiber Cable	31
7.2	Optical Fiber Connection	31
7.2.1	Connection insertion loss	31
7.2.2	Maximum discrete reflectance	31
7.3	Medium Dependent Interface (MDI) Requirement	31
8	400G-FR4-3-OPEN EYE MODULE COLOR CODING	32

## TABLES

Table 4-1: 400G-FR4-3-Open Eye operating range.....	10
Table 4-2: 400G-FR4-3-Open Eye transmit characteristics.....	11
Table 4-3: 400G-FR4-3-Open Eye receive characteristics.....	12
Table 4-4: 400G-FR4-3-Open Eye illustrative power budget.....	13
Table 4-5: 400G-FR4-3-Open Eye Maximum value for each discrete reflectance .....	13
Table 5-1: Test patterns .....	14
Table 5-2: Test pattern definitions and related subclauses .....	14
Table 5-3: Eye Mask Values for 400G-FR4-3-Open Eye .....	24
Table 5-4: Transmitter compliance channel specifications .....	25
Table 5-5: Sinusoidal jitter frequency for TP3 testing .....	29
Table 6-1: Fiber optic cabling (channel) characteristics .....	30
Table 7-1: Optical fiber and cable characteristics.....	31
Table 8-1: 400G-FR4-3-Open Eye Module Color Coding .....	32

## FIGURES

Figure 3-1: Block diagram for 400G-FR4-3-Open Eye transmit/receive paths.....	9
Figure 5-1: P3 Level Measurement.....	15
Figure 5-2: P0 Level Measurement.....	16
Figure 5-3: Test set up for 400G-FR4-3-Open Eye transmitter output.....	19
Figure 5-4: TP2 PAM4 Eye Parameters for 400G-FR4-3-Open Eye.....	23
Figure 5-5: Eye Mask for 400G-FR4-3-Open Eye .....	24
Figure 5-6: Receiver sensitivity as a function of $VEC_{stat}$ .....	26
Figure 5-7: Stressed Receiver Test block diagram .....	27
Figure 5-8: Receiver input sinusoidal jitter.....	29
Figure 6-1: Fiber optic cabling model .....	30

# 1 References and Conventions

## 1.1 Industry Documents

The following documents are relevant to this specification:

InfiniBand  
IEEE 802.3 2018  
OIF CEI

## 1.2 Sources

Copies of InfiniBand standards may be obtained from the InfiniBand Trade Association (IBTA) (<http://www.infinibandta.org>).

Copies of IEEE standards may be obtained from the Institute of Electrical and Electronics Engineers (IEEE) (<https://www.ieee.org>).

Copies of OIF Implementation Agreements may be obtained from the Optical Internetworking Forum (<http://www.oiforum.com>).

## 1.3 Conventions

The following conventions are used throughout this document:

### ORDER OF PRECEDENCE

If a conflict arises between text, tables, or figures, the order of precedence to resolve the conflicts is text; then tables; and finally figures. Not all tables or figures are fully described in the text. Tables show data format and values.

### LISTS

Lists sequenced by lowercase or uppercase letters show no ordering relationship between the listed items. Lists sequenced by numbers show an ordering relationship between the listed items. Lists are associated with an introductory paragraph or phrase, and are numbered relative to that paragraph or phrase (i.e., all lists begin with an a. or 1. entry).

### NUMBERING CONVENTIONS

The ISO convention of decimal numbering is used (i.e., the thousands and higher multiples are separated by a space and a period is used as the decimal point). This is equivalent to the English/American convention of a comma and a period.

American	French	ISO
0.6	0,6	0.6
1,000	1 000	1 000
1,323,462.9	1 323 462,9	1 323 462.9

## 2 Keywords, Acronyms, and Definitions

For the purposes of this document, the following keywords, acronyms, and definitions apply.

### 2.1 Keywords

**Optional:** Describes features which are not required by the specification. However, if any feature defined by the specification is implemented, it shall be done in the same way as defined by the specification. Describing a feature as optional in the text is done to assist the reader. If an optional feature is not implemented the default values for bits and bytes associated with this feature shall be zero unless otherwise stated.

**Shall:** Indicates a mandatory requirement. Designers are required to implement all such mandatory requirements to ensure interoperability with other products that conform to this specification.

**Should:** Indicates flexibility of choice with a strongly preferred alternative.

**Vendor specific:** Indicates something (e.g., a bit, field, code value) that is not defined by this specification. Specification of the referenced item is determined by the manufacturer and may be used differently in various implementations.

### 2.2 Acronyms and Abbreviations

**ASCII:** American Standard Code for Information Interchange (the numerical representation of a character)

**BER:** Bit Error Rate

**CDR:** Clock and Data Recovery

**DFB:** Distributed Feedback Laser

**DWDM:** Dense Wavelength Division Multiplexing

**EML:** Externally Modulated Laser

**FEC:** Forward Error Correction

**FP:** Fabry-Perot Laser

**SMF:** Single-Mode Fiber

**WDM:** Wavelength Division Multiplexing

## 2.3 Definitions

**P3 Level:** The P3 level is highest power level of the PAM4 signal.

**P0 Level:** The P0 level is the lowest power level of the PAM4 signal.

**OMA<sub>outer</sub>:** OMA<sub>outer</sub> is the level of modulated power in the optical signal based on low frequency P3 and P0 levels.

**Transmitter optical power (peak-peak)** is the level of modulated power in the optical signal including overshoots and undershoots. ( $OMA_{outer} \leq \text{Transmitter optical power (peak-peak)}$ )

**Average Power:** The Average Power,  $P_{av}$ , is the average of the optical power of the PAM4 signal.

**Lower Threshold:** The Lower Threshold is the threshold associated with the lower eye of the PAM4 signal.

**Middle Threshold:** The Middle Threshold is associated with the middle eye of the PAM4 signal.

**Upper Threshold:** The Upper Threshold is associated with the upper eye of the PAM4 signal.

**UI<sub>mid</sub>:** UI<sub>mid</sub> is specified as being 0.5 UI after 0 UI.

**Middle Eye Center:** The Middle Eye Center is calculated from eye width and eye height measurements of the middle eye. It is used to position the center of the mask shape for the middle eye mask.

**Lower Eye Center:** The Lower Eye Center is calculated from eye width and eye height measurements of the lower eye. It is used to position the center of the mask shape for the lower eye mask.

**Upper Eye Center:** The Upper Eye Center is calculated from eye width and eye height measurements of the upper eye. It is used to position the center of the mask shape for the upper eye mask.

**P<sub>3\_mean</sub>, P<sub>2\_mean</sub>, P<sub>1\_mean</sub>, P<sub>0\_mean</sub>:** These levels are calculated using the levels determined from by histograms centered on the Middle Eye Center and are calculated during Transmitter Test 1.

**DC Balance:** DC Balance is a measure of level symmetry about the average power level. This is used to evaluate contributions to DC wander caused by the pattern. This is evaluated during Transmitter Test 1.

**Symbol Level Symmetry:** Symbol Level Symmetry is a measure of how evenly the four levels are distributed in amplitude. Symbol Level Symmetry is an indicator of the penalty caused by uneven PAM4 levels. This is evaluated during Transmitter Test 1.

**EH<sub>low</sub>, EH<sub>mid</sub>, EH<sub>upp</sub>:** EH<sub>low</sub>, EH<sub>mid</sub> and EH<sub>upp</sub> are the inner eye heights associated with the lower, middle and upper eyes respectively measured using a histogram method around the Middle Eye Center. This is evaluated during Transmitter Test 1.

## 400G-FR4-3 Technical Specifications Rev 2.0

---

**EW<sub>low</sub>, EW<sub>mid</sub>, EW<sub>upp</sub>:** EW<sub>low</sub>, EW<sub>mid</sub> and EW<sub>upp</sub> are the inner eye widths associated with the lower, middle and upper eyes respectively measured at the eye centers. This is evaluated during Transmitter Test 1.

**Vertical Eye Closure Deterministic (VEC<sub>det</sub>):** Vertical Eye Closure Deterministic (VEC<sub>det</sub>) is defined as the amount of eye closure with respect to OMA<sub>outer</sub> based on the smallest inner eye height. This is evaluated during Transmitter Test 1.

**Vertical Eye Closure Statistical (VEC<sub>stat</sub>):** The Vertical Eye Closure Statistical (VEC<sub>stat</sub>) is used to assess the vertical eye closure of the transmitter using a long pattern. This is evaluated during Transmitter Test 2.

**Module:** Pluggable transceivers and active or passive cable assembly terminations that plug into the host receptacle such as, but not limited to, those of QSFP-DD, OSFP, COBO, QSFP, and SFP-DD form factors - hereafter referred to as modules unless cable assemblies are specifically mentioned.

**OSNR:** Optical Signal to Noise Ratio: The ratio between the optical signal power in a given signal bandwidth and the noise power in a given noise reference bandwidth.

**Pulse Amplitude Modulation, four levels (PAM4):** a modulation scheme where two bits are mapped into four signal amplitude levels to enable transmission of two bits per symbol.

**Rx:** an electronic component (Rx) that converts an electrical input signal to an electrical (retimed or non-retimed) output signal.

**SNR:** Signal to Noise Ratio: The ratio of signal power to the noise power, expressed in decibels.

**Tx:** a circuit (Tx) that converts an electrical input signal to a signal suitable for the optical communications media.



### 3 GENERAL

#### 3.1 Scope

This Open Eye Multi-Source Agreement (MSA) specification defines a four lane 100 Gbps/lane 3km optical interface for 400 Gbps optical transceivers for Ethernet applications. Forward error correction (FEC) is required to be implemented by the host in order to ensure reliable system operation. Two transceivers communicate over single mode fibers (SMF) of length from 2 meters to at least 3 kilometers using the 400G-FR4-3-Open Eye specification. The transceiver electrical interface is not specified by this MSA but can have, for example, eight lanes in each direction with a nominal rate of 106.25 Gbps per lane or four lanes in each direction with a nominal rate of 106.25 Gbps per lane.

The 400G-FR4-3-Open Eye specification is based upon the IEEE802.3cu 2 km link budget with modified dispersion parameters to account for 3 km operation. The loss budget is unchanged. Operation over 3 km requires lower loss fiber than the worst case specified in the Fiber Optic Cabling requirements (Section 7) or lower connector and splice loss.

A variety of form factors for the 400G-FR4-3-Open Eye transceiver are possible and none is precluded by this MSA.

#### 3.2 400G-FR4-3 Open Eye Module Block Diagram

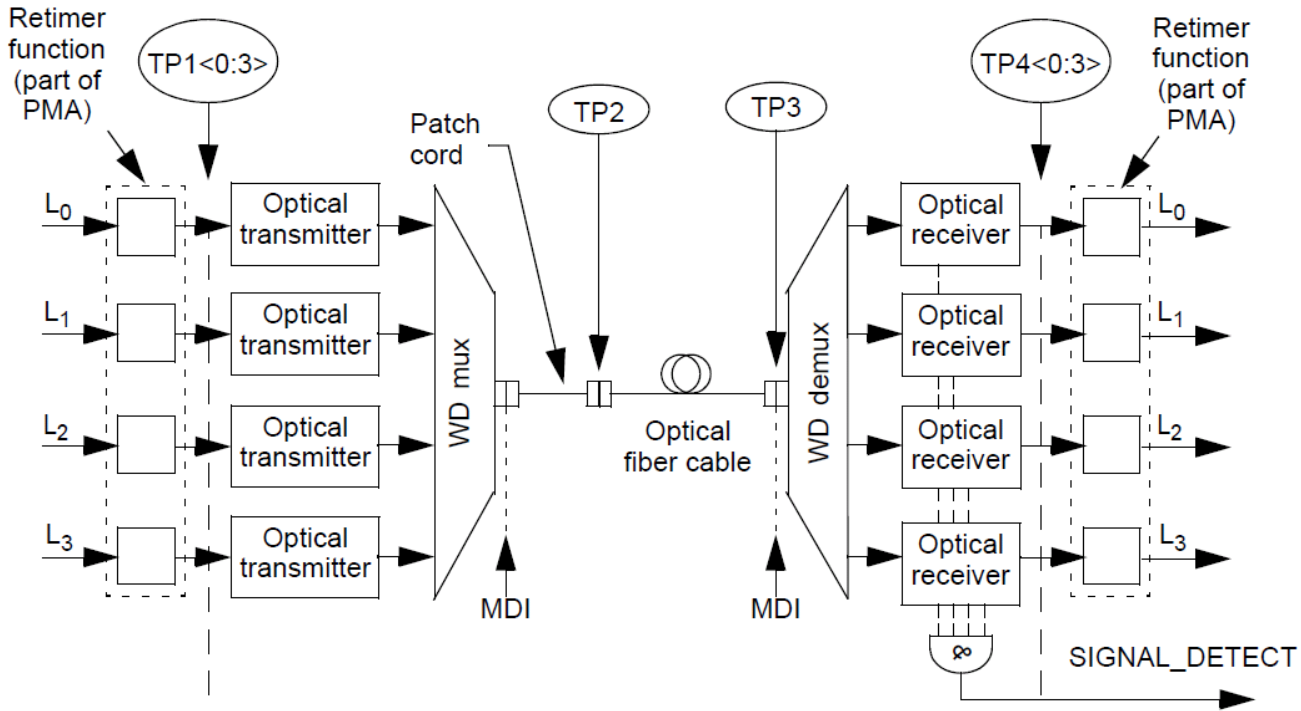

NOTE – Specification of the retimer function is beyond the scope of this MSA.

Figure 3-1: Block diagram for 400G-FR4-3-Open Eye transmit/receive paths

#### 3.3 Functional Description

400G-FR4-3-Open Eye modules comply with the requirements of this document and have the following common features: one optical transmitter; one optical receiver with signal detect and a duplex optical connector for single-mode fiber. The optical connector type is vendor specific but can include SC, LC, MPO, SN or CS types.

### 3.4 Hardware Signaling Pins

Hardware signaling pins are specified in the respective module form factor MSAs.

### 3.5 Module Management Interface

The contents of the various ID registers shall comply with the requirements of the module MSA and the respective standards.

### 3.6 FEC Requirements

The host system is required to enable RS(544,514) FEC (“KP4 FEC”) in accordance with clause 119 of IEEE Std 802.3-2018<sup>TM</sup>. Operation with other FEC codes is beyond the scope of this MSA.

### 3.7 High Speed Electrical Characteristics

The detailed high speed electrical characteristics are not defined by this MSA.

### 3.8 Mechanical Dimensions

Mechanical dimensions are defined in module form factor MSA specifications.

## 4 400G-FR4-3-OPEN EYE OPTICAL SPECIFICATIONS

### 4.1 Optical Specifications

The operating range for the 400G-FR4-3-Open Eye PMDs is defined in Table 4-1. A compliant PMD operates on single-mode fibers according to the specifications defined in Table 6-1 and characteristics in Table 7-1. A PMD that exceeds the required operating range while meeting all other optical specifications is considered compliant (e.g., operating at 3.5 km meets the operating range requirement of 2 m to 3 km).

**Table 4-1: 400G-FR4-3-Open Eye operating range**

PMD type	Required operating range
400G-FR4-3-Open Eye	2 m to 3 km

During optimization of the transmitter, the aim should be to maximize the mask margin for each of the three inner eyes simultaneously whilst trading off against other parameters within the limits specified.

The following transmitter tests are considered informative:

1.  $VEC_{det}$  (covered by eye mask test)
2. Vertical Eye Opening (covered by eye mask test)
3. Horizontal Eye Opening (covered by eye mask test)

# 400G-FR4-3 Technical Specifications Rev 2.0

## 4.1.1 400G-FR4-3-Open Eye transmitter optical specifications

The 400G-FR4-3-Open Eye Transmitters shall meet the specifications defined in Table 4-2.

**Table 4-2: 400G-FR4-3-Open Eye transmit characteristics**

Description	400GBASE-FR4 <sup>a</sup>	400G-FR4-3-Open Eye	Unit
PAM4 Signaling rate (fb), (range)	53.125 ± 100 ppm	53.125 ± 100 ppm	GBd
Modulation format	PAM4	PAM4	
Wavelength (range)	1264.5 to 1277.5 1284.5 to 1297.5 1304.5 to 1317.5 1324.5 to 1337.5	1264.5 to 1277.5 1284.5 to 1297.5 1304.5 to 1317.5 1324.5 to 1337.5	nm
Side-mode suppression ratio (SMSR), (min)	30	30	dB
Total average launch power (max)	10.4	10.4	dBm
Average launch power ( $P_{av}$ ), each lane (max)	4.4	4.4	dBm
Average launch power ( $P_{av}$ ), each lane <sup>b</sup> (min)	-3.2	-3.2	dBm
Transmitter optical power, each lane (peak-peak) (max)		3.7	dBm
Outer Optical Modulation Amplitude ( $OMA_{outer}$ ), each lane (max)	3.7	3.7	dBm
Outer Optical Modulation Amplitude ( $OMA_{outer}$ ), each lane (min) For $VEC_{stat} < 1.4$ dB For $1.4 \text{ dB} \leq VEC_{stat} \leq 3.4$ dB	-0.2 -1.6 + TDECQ	-0.2 -1.6 + $VEC_{stat}$	dBm
Difference in launch power between any two lanes ( $OMA_{outer}$ ) (max)	3.9	3.9	dB
TDECQ	3.4	NA	dB
$VEC_{det}$ (Vertical Eye Closure, deterministic) <sup>c</sup> (max)		5.2	dB
$VEC_{stat}$ (Vertical Eye Closure, statistical) <sup>d</sup> (max)		3.4	dB
Vertical Eye Opening ( $EH_{upp}$ , $EH_{mid}$ , $EH_{low}$ ) ( $OMA$ ) <sup>c,d</sup> (min)		+/-0.05	$OMA_{outer}$
Horizontal Eye Opening ( $EW_{upp}$ , $EW_{mid}$ , $EW_{low}$ ) <sup>c</sup> (min)		0.17	UI
DC Balance (max)		0.1	
Symbol level symmetry		0.90	
Average launch power of OFF transmitter, (max)	-30	-30	dBm
Extinction ratio, each lane (min)	3.5	3.5	dB
Optical return loss tolerance (max)	17.1	17.1	dB
Transmitter reflectance <sup>e</sup> (max)	-26	-26	dB
$RIN_{17.1}$ OMA (max)	-132	-132	dB/Hz

<sup>a</sup>Value provided for reference only, see IEEE 802.3 for current version. Some parameters from IEEE802.3cu are not included (such as overshoot, undershoot and power excursion) as these are captured in the eye mask test.

<sup>b</sup>Average launch power, each lane (min) is informative and not the principal indicator of signal strength. A transmitter with launch power below this value cannot be compliant; however, a value above this does not ensure compliance.

<sup>c</sup>Vertical and horizontal Eye Opening must be compliant with the eye mask shown in Figure 5-5.

<sup>d</sup>For specifications using  $VEC_{stat}$ , any value of  $VEC_{stat} < 1.4$ dB shall be assigned a value of 1.4dB.

<sup>e</sup>Transmitter reflectance is defined looking into the transmitter

# 400G-FR4-3 Technical Specifications Rev 2.0

## 4.1.2 400G-FR4-3-Open Eye receive optical specifications

The 400G-FR4-3-Open Eye receiver shall meet the specifications defined in Table 4-3.

**Table 4-3: 400G-FR4-3-Open Eye receive characteristics**

Description	400GBASE-FR4 Value <sup>a</sup>	400G-FR4-3-Open Eye	Unit
Signaling rate (fb), each lane (range)	53.125 ± 100 ppm	53.125 ± 100 ppm	GBd
Modulation format	PAM4	PAM4	
Wavelength (range)	1264.5 to 1277.5 1284.5 to 1297.5 1304.5 to 1317.5 1324.5 to 1337.5	1264.5 to 1277.5 1284.5 to 1297.5 1304.5 to 1317.5 1324.5 to 1337.5	nm
Damage threshold, (min) <sup>b</sup>	5.4	5.4	dBm
Average receive power, each lane (max)	4.4	4.4	dBm
Average receive power, <sup>c</sup> each lane (min)	-7.2	-7.2	dBm
Receive power, (OMA <sub>outer</sub> ) each lane (max)	3.7	3.7	dBm
Difference in receive power between any two lanes (OMA <sub>outer</sub> )(max)	4.1	4.1	dB
Receiver optical power, each lane (peak-peak) (max)		3.7	dBm
Receiver reflectance (max)	-26	-26	dB
Receiver sensitivity (OMA <sub>outer</sub> ), (max) For VEC <sub>stat</sub> < 1.4 dB For 1.4 dB ≤ VEC <sub>stat</sub> ≤ 3.4 dB	-4.6 -6 + TECQ	-4.6 -6 + VEC <sub>stat</sub>	dBm
Stressed receiver sensitivity (OMA <sub>outer</sub> ), <sup>d</sup> (max)	-2.6	-2.6	dBm
Conditions of stressed receiver sensitivity test <sup>e</sup> :			
OMA <sub>outer</sub> of each aggressor lane	1.4	1.4	dBm
Stressed input Eye Height VEC <sub>stat</sub>	NA	3.4	dB
Stressed input Eye Height (SECQ)	3.4		dB

<sup>a</sup> Value provided for reference only, see IEEE 802.3cu for current version.

<sup>b</sup>The receiver shall be able to tolerate, without damage, continuous exposure to an optical signal having this average power level. The receiver does not have to operate correctly at this input power.

<sup>c</sup>Average receive power, (min) is informative and not the principal indicator of signal strength. A received power below this value cannot be compliant; however, a value above this does not ensure compliance.

<sup>d</sup>Measured with conformance test signal at TP3 (see 5.27) for the BER specified in IEEE Std 802.3cu clause 151.8.13.

<sup>e</sup>These test conditions are for measuring stressed receiver sensitivity. They are not characteristics of the receiver. See Figure 5-7

### 4.1.3 400G-FR4-3-Open Eye illustrative link power budget

An illustrative power budget and penalties for 400G-FR4-3-Open Eye are shown in Table 4-4.

**Table 4-4: 400G-FR4-3-Open Eye illustrative power budget**

Description	400G-FR4-3-Open Eye Value	Unit
Power budget	7.8	dB
Operating distance	3.0	km
Channel insertion loss <sup>a</sup>	4.0	dB
Maximum discrete reflectance	See Table 4-5	dB
Allocation for penalties <sup>b</sup>	3.8	dB
Additional insertion loss allowed	0	dB
<p><sup>a</sup>The channel insertion loss is calculated using the maximum distance specified in Table 4-1 and cabled optical fiber attenuation of 0.5 dB/km at 1304.5 nm plus an allocation for connection and splice loss given in 7.2.1. For operation over 3 km, either lower loss fiber than the worst case specified in the Fiber Optic Cabling Requirements (Section 7) or lower connector and splice loss is required.</p> <p><sup>b</sup>Link penalties are used for link budget calculations. They are not requirements and are not meant to be tested.</p>		

**Table 4-5: 400G-FR4-3-Open Eye Maximum value for each discrete reflectance**

Number of discrete reflectances above -55 dB	Maximum value for each discrete reflectance	Unit
≤4	-35	dB
6	-38	dB
8	-40	dB
10	-41	dB

## 5 DEFINITION OF OPTICAL PARAMETERS AND MEASUREMENT METHODS

All optical measurements shall be made through a short patch cable, between 2 m and 5 m in length, unless otherwise specified.

### 5.1 Test Patterns for Optical Parameters

**Table 5-1: Test patterns**

Pattern	Pattern Description	Defined in <sup>a</sup>
Square wave	Square wave (8 threes, 8 zeroes)	120.5.11.2.4
3	PRBS31Q	120.5.11.2.2
4	PRBS13Q	120.5.11.2.1
5	Scrambled idle encoded by RS-FEC	119.2.4.9
5a	Scrambled Remote Fault encoded by RS-FEC	119.2.3.8, 82.2.3.9, 117.3, 81.3.4
6	SSPRQ	120.5.11.2.3

<sup>a</sup>These sub-clauses make reference to relevant clauses of IEEE Std 802.3-2018.

**Table 5-2: Test pattern definitions and related subclauses**

Parameter	Pattern	Reference
Wavelength	Square wave, 3, 4, 5, 5a, 6 or valid 400GBASE-R signal	5.4
Side mode suppression ratio	3, 5, 5a, 6 or valid 400GBASE-R signal	140.7.2 <sup>a</sup>
Average optical power	3, 5, 5a, 6 or valid 400GBASE-R signal	5.5
Optical modulation amplitude (OMA <sub>outer</sub> )	4 or 6	5.8
Transmitter test 1: Short pattern deterministic test	4	5.22
Transmitter test 2: Long pattern statistical test	3 or 6 or valid 400GBASE-R signal	5.22
Extinction ratio	4 or 6	5.23
RIN <sub>17.1</sub> OMA	Square-wave	5.24
Stressed receiver conformance test signal calibration	6	5.27
Receiver sensitivity	3, 5 or 5a	5.26
Stressed receiver sensitivity	3, 5 or 5a	5.27

<sup>a</sup>IEEE Std 802.3cd™.

### 5.2 Inter-Eye Skew

The Inter-eye Skew is defined in Table 5-3. It is the maximum time difference between T<sub>mid,mid</sub> and T<sub>mid,upp</sub> or T<sub>mid,low</sub>. (See Figure 5-5)

### 5.3 Skew Variation

Skew variation is specified in IEEE Std 802.3 2018 clause 122.3.2.

## 5.4 Wavelength

The wavelength and SMSR shall be within the range given in Table 4-2 if measured per IEC 61280-1-3. The transmitter is modulated using the test pattern defined in Table 5-2.

## 5.5 Average Optical Power ( $P_{av}$ )

The average optical power shall be within the limits given in Table 4-2 if measured using the methods given in IEC 61280-1-1. The average optical power is measured using the test pattern defined in Table 5-2, per the test setup in IEEE Std 802.3-2018 Figure 53-6.

## 5.6 P3 Level

For Transmitter Test 1, the P3 Level is defined as the as the power measured over the central 2 UI of a run of 7 threes as shown in Figure 5-1

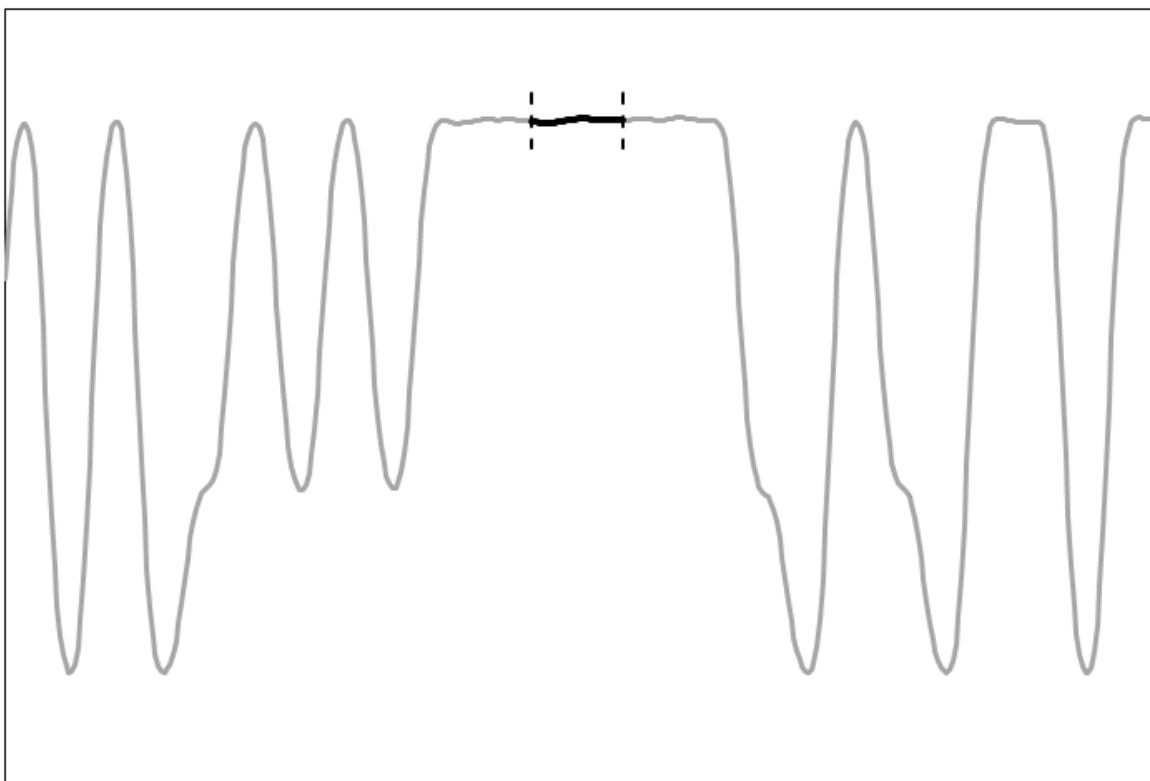

Figure 5-1: P3 Level Measurement

## 5.7 P0 Level

For Transmitter Test 1, the P0 Level is defined as the power measured over the central 2 UI of a run of 6 zeros as shown in Figure 5-2.

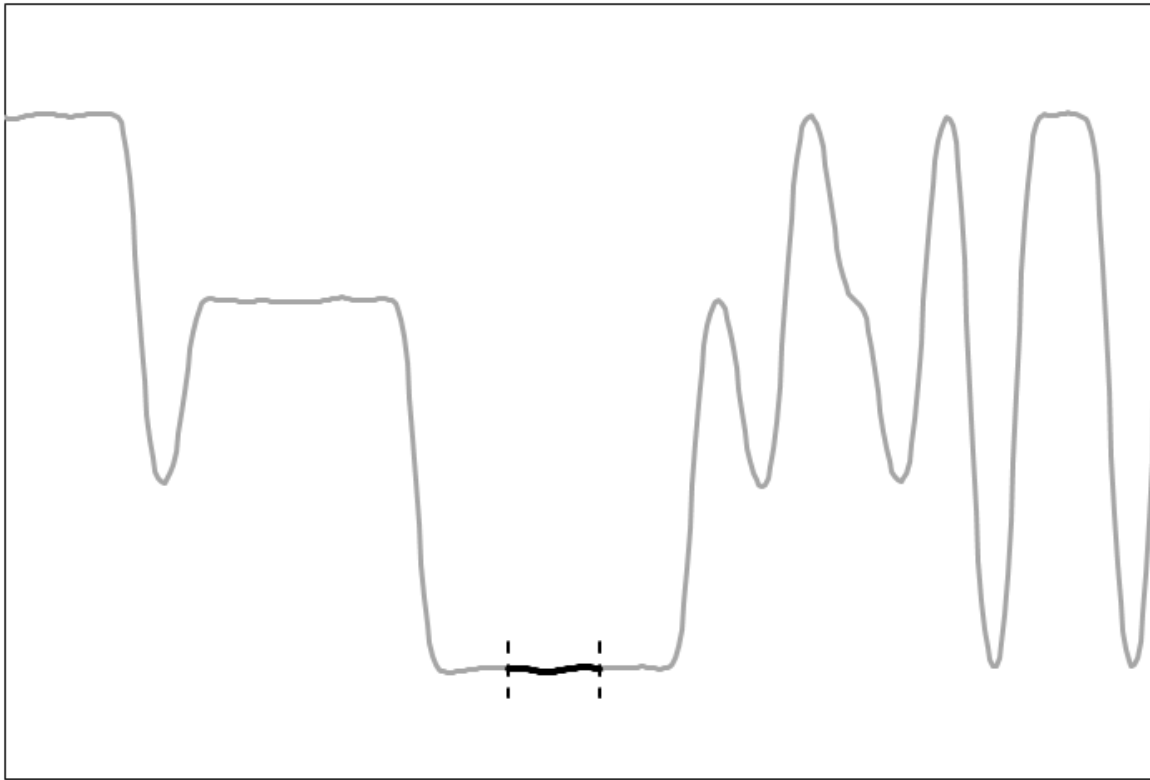

Figure 5-2: P0 Level Measurement

### 5.8 Optical Modulation Amplitude ( $OMA_{outer}$ )

$OMA_{outer}$  is calculated as (following IEEE Std 802.3 clause 122.8.4.)

$$OMA_{outer} = P_3 - P_0$$

### 5.9 Transmitter optical power (peak-peak)

Transmitter optical power (peak-peak) is measured as the outer envelope of the optical signal using the Reference Rx. The average waveform should be scanned to find the maximum and minimum power levels including overshoots and undershoots.

### 5.10 Lower Threshold

The Lower Threshold is calculated as

$$Lower\ Threshold = P_{av} - \frac{OMA_{outer}}{3}$$

### 5.11 Middle Threshold

The Middle Threshold is calculated as

$$Middle\ Threshold = P_{av}$$



## 5.12 Upper Threshold

The Upper Threshold is calculated as

$$\text{Upper Threshold} = P_{av} + \frac{OMA_{outer}}{3}$$

## 5.13 $UI_{mid}$

The mean of the average power crossing time is used to calculate the 0 UI time.  $UI_{mid}$  is 0.5 UI after 0 UI.

## 5.14 Middle Eye Center

Determine the time position associated with the midpoint of the horizontal eye width based on the zero hit crossing points at the Middle Threshold power level ( $P_{av}$ ). Constrain this time position with respect to the  $UI_{mid}$  times as per the requirements in Table 5-3. The constrained time position is defined as  $T_{mid,mid}$  (see Figure 5-4). This is the Middle Eye Center time position.

Determine the power level value associated with the mid-point of the middle eye vertical eye height based on the zero hit points measured at the Middle Eye Center time position. Constrain this power level value with respect to the Middle Threshold level to be within the requirements of Table 5-3. This is the Middle Eye Center amplitude value.

The mask shape for the middle eye is centered on the Middle Eye Center. The mask shape position can be optimized within the constraints defined in Table 5-3 with respect to  $UI_{mid}$  and the Middle Threshold power level.

## 5.15 Lower Eye Center

Determine the time position associated with the midpoint of the horizontal eye width based on the zero hit crossing points at the Lower Threshold power level. Constrain this time position to be within the Inter-eye Skew (max) specified in Table 5-3 of the Middle Eye Center time position. The constrained time position is defined as  $T_{mid,low}$  (see Figure 5-4). This is the Lower Eye Center time position.

Determine the power level value associated with the mid-point of the lower eye vertical eye height based on the zero hit points measured at the Lower Eye Center time position. Constrain this power level value to be within the requirements of Table 5-3. This is the Lower Eye Center amplitude value.

The mask shape for the lower eye is centered on the Lower Eye Center.

## 5.16 Upper Eye Center

Determine the time position associated with the midpoint of the horizontal eye width based on the zero hit crossing points at the Upper Threshold power level. Constrain this time position to be within the Inter-eye Skew (max) specified in Table 5-3 of the Middle Eye Center time position. The constrained time position is defined as  $T_{mid,upp}$  (see Figure 5-4). This is the Upper Eye Center time position.

Determine the power level value associated with the mid-point of the upper eye vertical eye height based on the zero hit points measured at the Upper Eye Center time position. Constrain this power level value to be within the requirements of Table 5-3. This is the Upper Eye Center amplitude value.

The mask shape for the upper eye is centered on the Upper Eye Center.

### 5.17 $P_{3\_mean}$ , $P_{2\_mean}$ , $P_{1\_mean}$ , $P_{0\_mean}$

These levels are calculated using the levels determined by histograms from a 0.05 UI wide window centered on the Middle Eye Center. The mean values are calculated from the histograms for each level.

### 5.18 DC Balance

DC Balance is a measure of level symmetry about the mid-power level and is referenced to the  $OMA_{outer}$ . This is to minimize contributions to DC wander. DC Balance is calculated using the levels determined from by histograms from a 0.05 UI wide window centered on the Middle Eye Center.

$$DC\ Balance = \frac{P_{0\_mean} + P_{1\_mean} + P_{2\_mean} + P_{3\_mean} - 4P_{av}}{P_{3\_mean} - P_{0\_mean}}$$

### 5.19 Symbol Level Symmetry

Symbol Level Symmetry is a measure of how even the four levels are distributed in amplitude. Symbol Level Symmetry is an indicator of the penalty caused by uneven PAM4 levels and is calculated using the levels determined from by histograms from a 0.05 UI wide window centered on the Middle Eye Center.

$$Symbol\ Level\ Symmetry = \frac{3 \cdot \min(P_{3\_mean} - P_{2\_mean}, P_{2\_mean} - P_{1\_mean}, P_{1\_mean} - P_{0\_mean})}{(P_{3\_mean} - P_{0\_mean})}$$

### 5.20 $EH_{low}$ , $EH_{mid}$ , $EH_{upp}$

$EH_{low}$ ,  $EH_{mid}$  and  $EH_{upp}$  are the inner eye heights associated with the lower, middle and upper eyes respectively. They are calculated using histogram edges from a 0.05 UI window centered on the Middle Eye Center. (See Figure 5-4)

### 5.21 $EW_{low}$ , $EW_{mid}$ , $EW_{upp}$

$EW_{low}$ ,  $EW_{mid}$  and  $EW_{upp}$  are the inner eye widths associated with the lower, middle and upper eyes respectively. These are measured at Lower Eye Center, Middle Eye Center and Upper Eye Center points using the innermost transition crossing the Eye Center amplitude value. (See Figure 5-4)

### 5.22 Transmitter Eye and VEC Measurements

Two transmitter tests are performed to ensure compliance to the performance defined in Table 4-2. The test set up shown in Figure 5-3 is used for both Transmitter Test 1 and Transmitter Test 2. The purpose of Transmitter Test 1 is to ensure the eye has low ISI over the mid and upper frequency ranges and that the eye

is centered. An eye mask test is performed during transmitter test 1 and no mask violations are allowed. The eye mask is not a hit ratio mask. Transmitter Test 2 uses a longer pattern to cover the full frequency range and fully characterize the transmitter using a statistical measurement.

The signal at TP2 is used to measure Eye Width (EW), Eye Height (EH), DC Balance, Symbol Symmetry and Vertical Eye Closure. The measured signal after the reference receiver shall meet the specifications listed in Table 4-2, using a test pattern as defined in Table 5-2. The definitions of the eye parameters and equations are defined in Section 2.3.

The test set up for measuring transmitter output Eye Width and Eye Height is illustrated in Figure 5-3.

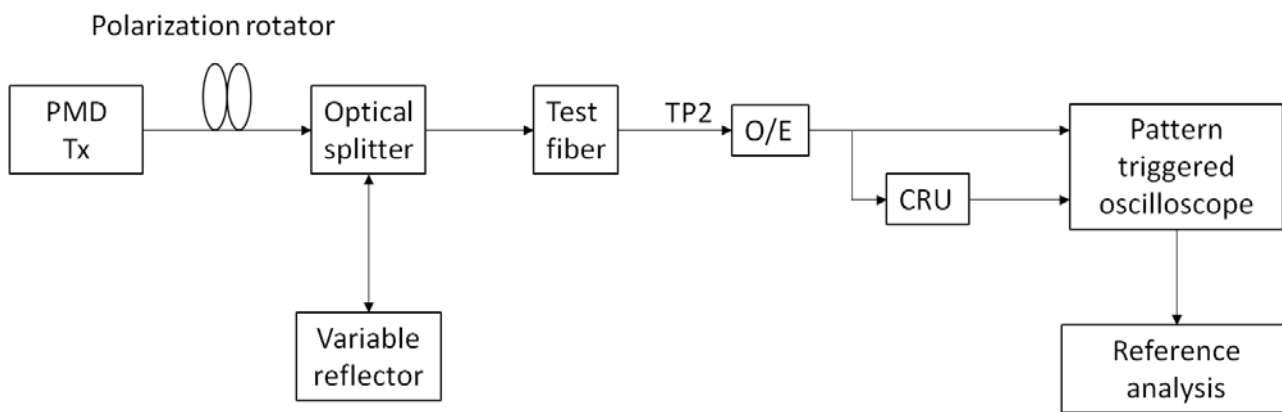

**Figure 5-3: Test set up for 400G-FR4-3-Open Eye transmitter output**

### 5.22.1 Transmitter Test 1: Short pattern deterministic test

This test is to ensure the transmitter has good mid and high frequency characteristics with low ISI and is centered.

- 1) Set the PPG or host to the correct pattern as defined in Table 5-2. This allows the sampling oscilloscope to use pattern lock.
- 2) Capture the signal at TP2 using the reference receiver as defined in Section 5.25 with an oscilloscope triggered with a clock from a reference clock recovery unit (CRU) with a first order transfer function with a 3 dB tracking bandwidth of 4 MHz.
  - a. The signal must be captured with a minimum of 16 samples per UI with averaging of 4, or equivalent.
  - b. Every symbol must be overlaid to form the eye diagram.
  - c. The signal should be interpolated to have sample spacing of less than or equal to the eye diagram column width using  $\text{Sin}(x)/x$  interpolation.
- 3) Measure Transmitter optical power (peak-peak)
- 4) Determine  $T_{\text{mid}}$  and  $\text{OMA}_{\text{outer}}$ .
- 5) Determine the Middle Eye Center, Lower Eye Center and Upper Eye Center.

- 6) Apply the eye mask. The Middle, Lower and Upper Eye Centers can be optimized vertically and horizontally for best mask compliance within the constraints specified in Table 5-3. **No violations of the eye mask are allowed.**
- 7) Measure the  $P_{3\_mean}$ ,  $P_{2\_mean}$ ,  $P_{1\_mean}$  and  $P_{0\_mean}$  levels based on the peak of the histograms measured in a 0.05 UI wide vertical window centered on the Middle Eye Center.
- 8) Calculate DC Balance and Symbol Level Symmetry.
- 9) Measure eye height (EH) for each of the inner eyes and calculate Vertical Eye Closure Deterministic, ( $VEC_{det}$ ).
- 10) Measure eye width (EW) for each of the inner eyes at their measured Eye Centers.

### 5.22.1.1 Vertical Eye Closure Deterministic ( $VEC_{det}$ )

$VEC_{det}$  is a measure of the transmitter eye closure penalty based on the averaged pattern used in transmitter test 1. It is calculated using the measured eye heights,  $P_{3\_mean}$  and  $P_{0\_mean}$  levels.

$$VEC_{det}(dB) = -10 \cdot \log_{10} \left( \frac{3 \cdot \min(EH_{upp}, EH_{mid}, EH_{low})}{(P_{3\_mean} - P_{0\_mean})} \right)$$

### 5.22.2 Transmitter Test 2: Long pattern statistical test

This test is to ensure that the transmitter has good performance using a representative usage pattern and to calculate the link penalty associated with the transmitter when transmitting through a worst case optical channel, and measured using the reference receiver as defined in Section 5.25. The reference receiver may be implemented in software or may be part of the oscilloscope.

- 1) Set the PPG or host to the correct pattern as defined in Table 5-2.
- 2) Capture the eye diagram at TP2 using the reference receiver as defined in Section 5.25 with the oscilloscope triggered with a clock from a reference clock recovery unit (CRU) with a first order transfer function with a 3 dB tracking bandwidth of  $fb/6640$ .
- 3) Using the method described in the Vertical Eye Closure Statistical ( $VEC_{stat}$ ) (Section 5.22.2.1) capture sufficient samples to establish the BER curve at  $2.4 \times 10^{-4}$ . The outer height boundary of the histogram windows must encompass the full amplitude of the waveform.
- 4) Calculate Vertical Eye Closure statistical ( $VEC_{stat}$ ). For specifications using  $VEC_{stat}$ , any value of  $VEC_{stat} < 1.4$  dB shall be assigned a value of 1.4 dB.

Note: If test flexibility is required, then it is acceptable to have Test 2 stand-alone from Test 1 and to base the initial  $VEC_{stat}$  measurement on  $UI_{mid}$  and the Lower, Middle and Upper thresholds and allow optimization with the limits specified in Table 5-3. The OMA should be calculated using  $P_{0\_mean}$  and  $P_{3\_mean}$  calculations from the histograms for this test for patterns that cannot be pattern locked. It is expected that a pattern locked measurement will be more accurate.

**5.22.2.1 Vertical Eye Closure Statistical (VEC<sub>stat</sub>)**

The Vertical Eye Closure Statistical (VEC<sub>stat</sub>) is used to assess the vertical eye closure of the transmitter using a long pattern which is representative of the data traffic that the transmitter will pass in normal usage. It is also expected that VEC<sub>stat</sub> can be used to infer the receiver penalty compared to other transmitters.

The OMA<sub>outer</sub> of the transmitter signal being tested needs to be kept at a sufficient level to minimize the impact of oscilloscope noise. The oscilloscope noise should be characterized with no input signal. This is defined as  $\sigma_s$ .

Two vertical histograms of 0.02 UI width located at +/- 0.025 UI from the Middle Eye Center are measured through the PAM4 eye diagram. The outer height boundaries of the histograms must be set beyond the extremes of the eye diagram to ensure that all samples within the defined histogram time slices are captured. Each histogram (defined as left and right) should be divided into a suitable number of equally spaced, touching, bins spanning the optical power range sampled. Each bin contains a number of optical power samples,  $n_i$ , captured in the bin range,  $\Delta p$ , with the bin center at  $p_i$ . Each bin is normalized by dividing  $p_i$  by the total number of samples in that histogram.

$$\text{Normalized Histogram} = F(p_i) = \frac{n_i}{N_{\text{histogram}}}$$

$$\sum_i F(p_i) = 1$$

Convert each normalized histogram (left and right) into three cumulative probability functions, CPF<sub>Lupp</sub>, CPF<sub>Lmid</sub> and CPF<sub>Llow</sub> for the left histogram and CPF<sub>Rupp</sub>, CPF<sub>Rmid</sub> and CPF<sub>Rlow</sub> for the right histogram, centered on each of the Upper Eye Center, Middle Eye Center and Lower Eye Center power levels. The cumulative probability function, CPF<sub>Lupp</sub>, is calculated using:

$$CPF_{Lupp}(p_i) = \begin{cases} \sum_{p=Upper\ Eye\ Center}^{p_i} F(p) & \text{for } p \geq \text{Upper Eye Center} \\ \sum_{p_i} & \text{for } p < \text{Upper Eye Center} \end{cases}$$

The other cumulative probability functions are calculated using the appropriate eye center levels and normalized histograms.

To calculate the approximate Symbol Error Rate (SER), a Gaussian noise function needs to be iteratively convolved with the cumulative probability functions to find the SER of  $4.8 \times 10^{-4}$  (BER of  $2.4 \times 10^{-4}$ ). The Gaussian noise function is described as follows:

$$Noise_{upp}(p_i) = \int_{p_i - \frac{\Delta p}{2}}^{p_i + \frac{\Delta p}{2}} \frac{1}{\sigma_n \sqrt{2\pi}} \cdot e^{-\left(\frac{p - \text{Upper Eye Center}}{\sigma_n \sqrt{2}}\right)^2} dp$$

Which can be approximated as

$$Noise_{upp}(p_i) \approx \frac{1}{\sigma_n \sqrt{2\pi}} \cdot e^{-\left(\frac{p - Upper Eye Center}{\sigma_n \sqrt{2}}\right)^2} \cdot \Delta p$$

Where  $\sigma_n$  is the RMS value of Gaussian noise function. The equivalent Gaussian noise functions for the middle and lower eye cumulative probability functions are:

$$Noise_{mid}(p_i) \approx \frac{1}{\sigma_n \sqrt{2\pi}} \cdot e^{-\left(\frac{p - Middle Eye Center}{\sigma_n \sqrt{2}}\right)^2} \cdot \Delta p$$

$$Noise_{low}(p_i) \approx \frac{1}{\sigma_n \sqrt{2\pi}} \cdot e^{-\left(\frac{p - Lower Eye Center}{\sigma_n \sqrt{2}}\right)^2} \cdot \Delta p$$

The SER for the left histogram is calculated using

$$SER_L = \sum_i CPF_{Lupp}(p_i) \cdot Noise_{upp}(p_i) + \sum_i CPF_{Lmid}(p_i) \cdot Noise_{mid}(p_i) + \sum_i CPF_{Llow}(p_i) \cdot Noise_{low}(p_i)$$

The SER for the right histogram is calculated using

$$SER_R = \sum_i CPF_{Rupp}(p_i) \cdot Noise_{upp}(p_i) + \sum_i CPF_{Rmid}(p_i) \cdot Noise_{mid}(p_i) + \sum_i CPF_{Rlow}(p_i) \cdot Noise_{low}(p_i)$$

$\sigma_n$  is increased until either  $SER_L$  or  $SER_R$  reaches the target SER of  $4.8 \times 10^{-4}$ . The RMS sum of  $\sigma_n$  and  $\sigma_s$  is the equivalent RMS noise that could be added to the receiver.

$$Noise_{total} = \sqrt{\sigma_n^2 + \sigma_s^2}$$

The Vertical Eye Closure Statistical (VEC<sub>stat</sub>) penalty is calculated using

$$VEC_{stat}(dB) = 10 \log_{10} \left( \frac{OMA_{outer}}{6} \cdot \frac{1}{Q \cdot Noise_{total}} \right)$$

Where  $Q=3.414$  (SNR associated with the BER)

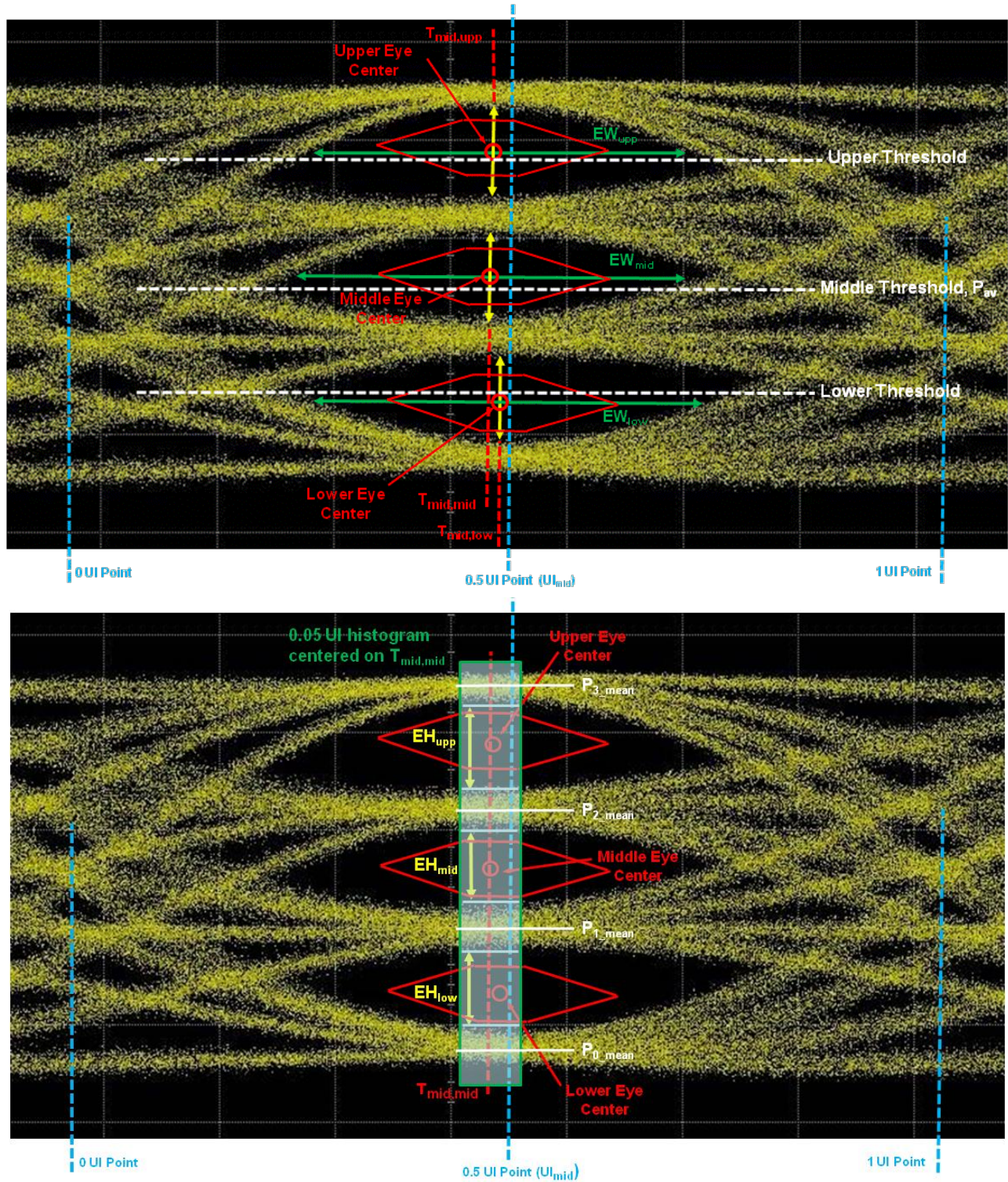
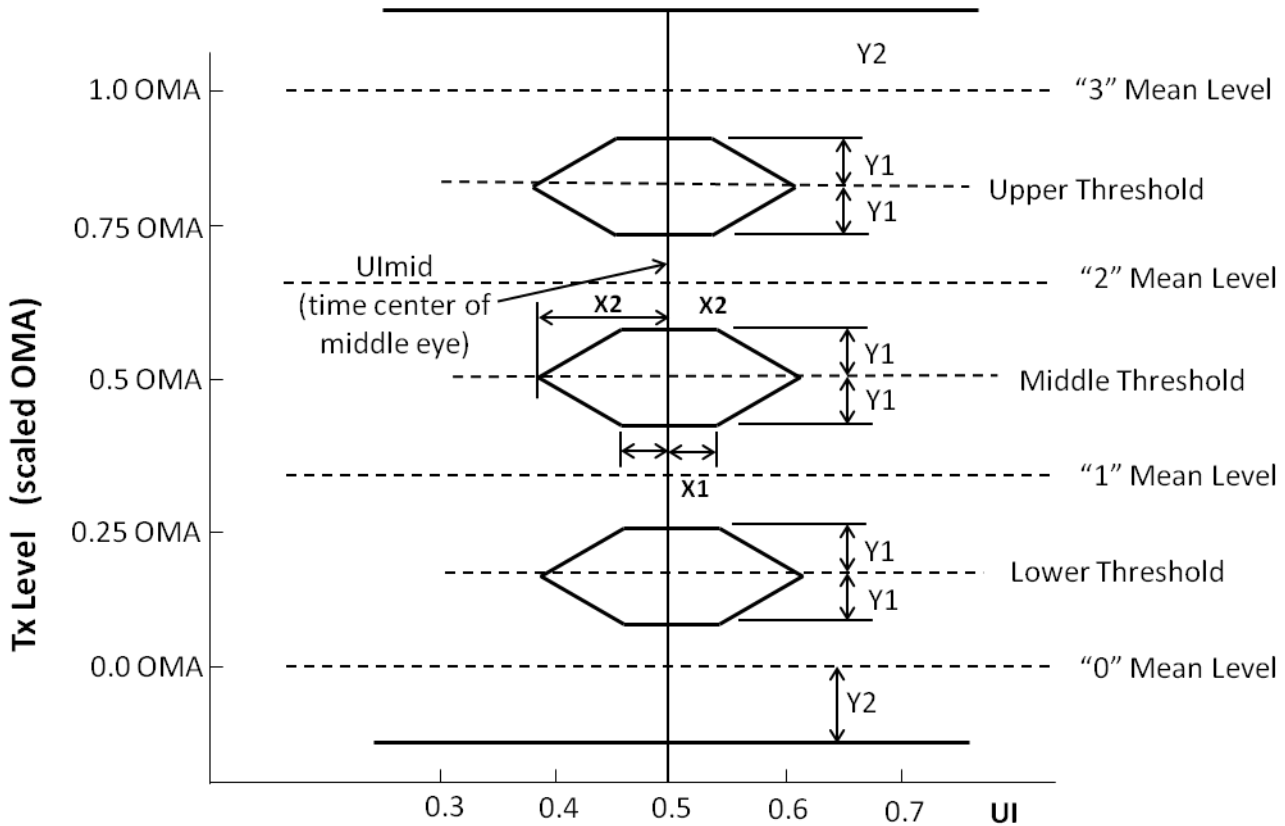

Figure 5-4: TP2 PAM4 Eye Parameters for 400G-FR4-3-Open Eye



Note: Upper and lower eye centers can be offset from the Middle Eye Center by no more than the Inter-eye Skew defined in Table 5-3.

Figure 5-5: Eye Mask for 400G-FR4-3-Open Eye

Table 5-3: Eye Mask Values for 400G-FR4-3-Open Eye

Description	400G-FR4-3-Open Eye Value	Unit
Vertical eye coordinates		
Y1	0.050	
Y2	0.25	
Horizontal eye coordinates		
X1	0.025	UI
X2	0.085	
Eye Center Constraints		
Vertical	+/- 2	% OMA <sub>outer</sub>
Horizontal		
Middle Eye Center (wrt UImid)	+/- 0.025	UI
Upper Eye Center (Lower Eye Center (wrt Middle Eye Center)	+/- 0.025	UI



**Table 5-4: Transmitter compliance channel specifications**

Type	Dispersion <sup>a</sup> (ps/nm)		Insertion loss <sup>b</sup>	Optical return loss <sup>c</sup>	Max mean DGD
	Minimum	Maximum			
400G-FR4-3-Open Eye	$0.070 * \lambda * [1 - (1324/\lambda)^4]$	$0.070 * \lambda * [1 - (1300/\lambda)^4]$	Minimum	17.1 dB	0.8 ps

<sup>a</sup>The dispersion is measured for the wavelength of the device under test ( $\lambda$  in nm). The coefficient assumes 3 km for 400G-FR4-3-Open Eye.

<sup>b</sup>There is no intent to stress the sensitivity of the BERT's optical receiver.

<sup>c</sup>The optical return loss is applied at TP2, i.e. after a 2 m patch cord.

### 5.23 Extinction Ratio

Extinction ratio is measured using the method specified in IEEE Std 802.3cd clause 140.7.6.

### 5.24 Relative Intensity Noise ( $RIN_{17.1OMA}$ )

RIN shall be as defined by the measurement methodology of IEEE Std 802.3-2018 clause 52.9.6 with the following exceptions:

- a) The optical return loss is 17.1 dB for 400G-FR4-3-Open Eye.
- b) The upper -3 dB limit of the measurement apparatus is to be approximately equal to the signaling rate (i.e., 53 GHz).

### 5.25 Reference Receiver

For the transmitter assessment (Test 1 and Test 2), the Reference Receiver is the combination of the O/E converter and the oscilloscope having a fourth-order Bessel Thomson filter response with a 3 dBe bandwidth of approximately 29.75 GHz (0.56\*baud rate) with a response out to at least 1.5 x baud rate. Above 1.5 x baud rate, the response should not exceed -24 dB.

For the Stressed Receiver Sensitivity test, the Reference Receiver is the combination of the O/E converter and the oscilloscope having a fourth-order Bessel Thomson filter response with a 3 dBe bandwidth of approximately 29.75 GHz (0.56\*baud rate) with a response out to at least 1.5 x baud rate. Above 1.5 x baud rate, the response should not exceed -24 dB.

### 5.26 Receiver Sensitivity

For 400G-FR4-3-Open Eye, receiver sensitivity is normative. The receiver shall comply with the equation for sensitivity across all measurements of eye closure. See Figure 5-6.

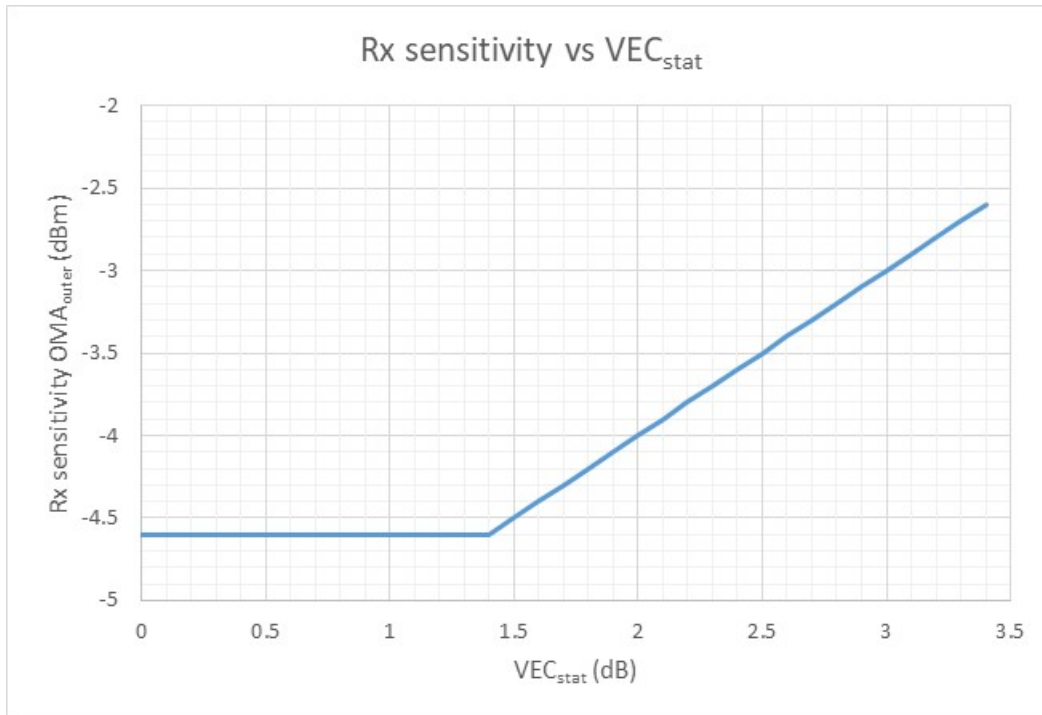

Figure 5-6: Receiver sensitivity as a function of VEC<sub>stat</sub>

### 5.27 Stressed receiver sensitivity

Stressed receiver sensitivity shall be within the limits given Table 4-3 when measured using the method defined in Sections 5.27.1 and 5.27.3 with the conformance test signal applied to TP3. The test pattern for stressed receiver sensitivity is specified in Table 5-1. The BER is required to be met for the lane under test on its own.

Stressed receiver sensitivity is defined with all transmit and receive lanes in operation. The transmitters for each lane are asynchronous to each other.

#### 5.27.1 Stressed receiver conformance test block diagram

A block diagram for the receiver conformance test is shown in Figure 5-7. The optical test signal is conditioned (stressed) using the methodology defined in Section 5.27.2 and sinusoidal jitter is applied as specified in Section 5.27.4. The stressed receiver conformance signal is verified using the techniques described in Section 5.27.3. Alternative test setups that generate equivalent stress conditions may also be used.

To ensure repeatability of the test signal calibration, all elements in the signal path should have a wide, smooth frequency response with linear phase and minimal reflections throughout the spectrum of interest. Baseline wander, overshoot and undershoot should be kept within the eye mask requirements.

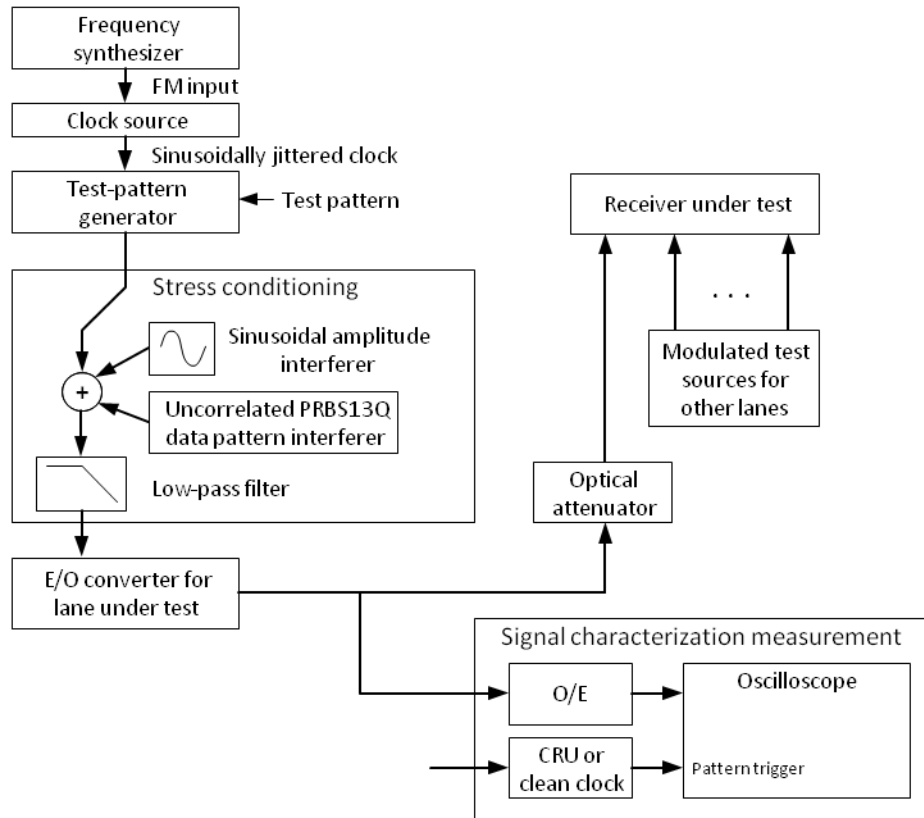

**Figure 5-7: Stressed Receiver Test block diagram**

A low pass filter is used to create ISI and the combination of the low-pass filter and E/O converter should have a smooth frequency response that results in sufficient ISI to give a  $VEC_{stat}$  as defined in Section 5.27.2. This eye closure is before any additional jitter and noise is added to the signal. The sinusoidal amplitude interferer and uncorrelated PRBS13Q pattern interferer are used to create additional eye closure. The frequency of the amplitude interferer can be set in the range of 100 MHz to 2 GHz with care being taken to avoid any harmonic relationships between the sinusoidal jitter, the signaling rate and the pattern repetition rate. The uncorrelated PRBS13Q data pattern interferer represents transmitter noise and crosstalk. The sinusoidal jitter added to the clock represents other forms of jitter and verifies that the receiver under test can track low frequency jitter. The sinusoidal jitter frequency should be between 50 kHz and 10 times loop bandwidth as defined in Table 5-5.

### 5.27.2 Stress receiver conformance test signal characteristics

The conformance test signal is used to validate that each lane of the receiver meets the BER requirements with near worst-case waveforms at TP3. Deterministic and sinusoidal jitter are added to a clean test pattern until the jitter at the output of the pattern generator approximates the informative transmit recommendations given in Table 4-2. The stressed receiver conformance test signal is measured using the setup described in Figure 5-7 except that the test fiber is not used. A laboratory grade E/O converter is assumed for this set up and measurement.

The stressed eye closure is set up as follows:

1. Set the signaling rate of the test pattern generator to meet the requirements in Table 4-2.
2. With the sinusoidal jitter, sinusoidal interferer and uncorrelated PRBS13Q data pattern interferer turned off, set the E/O converter extinction ratio approximately to the minimum specified in Table 4-2.

3. Add the filter and select the appropriate bandwidth to create ISI to give a  $VEC_{stat}$  of 2.3 dB to 2.8 dB.
4. Horizontal stressed eye closure is created by adding a  $>10 \times$  loop bandwidth (e.g. 250 MHz) sinusoidal clock applied to the test pattern generator clock. The amplitude of the jitter should be set to give 50 mUI (as shown in Figure 5-8).
5. The remaining stressed eye closure to achieve the  $VEC_{stat}$  specified in Table 4-3 is achieved by adding a 100 MHz sinusoidal interferer (25%) and an uncorrelated PRBS13Q data pattern interferer (75%).
6. Iterate the adjustments on the sinusoidal interferer amplitude, the uncorrelated PRBS13Q data pattern interferer and the extinction ratio until the required value of stressed eye closure ( $VEC_{stat}$ ) defined in Table 4-3 is met whilst simultaneously meeting the minimum extinction ratio and the jitter as specified in Table 4-2.
7. Each receiver lane is tested in turn. The stressed receiver conformance test signal is applied to the input of the receiver lane under test at the power specified as “Stressed receiver sensitivity ( $OMA_{outer}$ ), each lane (max)” in Table 4-3. The test sources for the other receiver lanes are set to “ $OMA_{outer}$  of each aggressor lane” specified in Table 4-3. The receiver should be capable of working with all reasonable combinations of stressors.

### 5.27.3 Stressed receiver conformance test signal verification

The stressed receiver conformance test signal is measured according to Figure 5-7. A separate clock source (clean clock in) is required to trigger the oscilloscope. This clock should be synchronized to the jittered clock source but not modulated with the jitter.

Care should be taken when characterizing the test signal because excessive noise/jitter in the measurement system would result in an input signal that does not fully stress the receiver under test. Running the receiver tolerance test with a signal that is under-stressed may result in the deployment of non-compliant receivers. The noise/jitter introduced by the O/E, filters, and oscilloscope should be negligible or the results should be corrected for its effects. The test equipment should be fully characterized and the measurement appropriately guard banded to ensure an accurate measurement is obtained.

**5.27.4 Sinusoidal jitter stressor for the receiver conformance test**

The sinusoidal jitter is used to test the receiver jitter tolerance. The amplitude of the applied sinusoidal jitter is frequency dependent and is specified in Table 5-5 and illustrated in Figure 5-8.

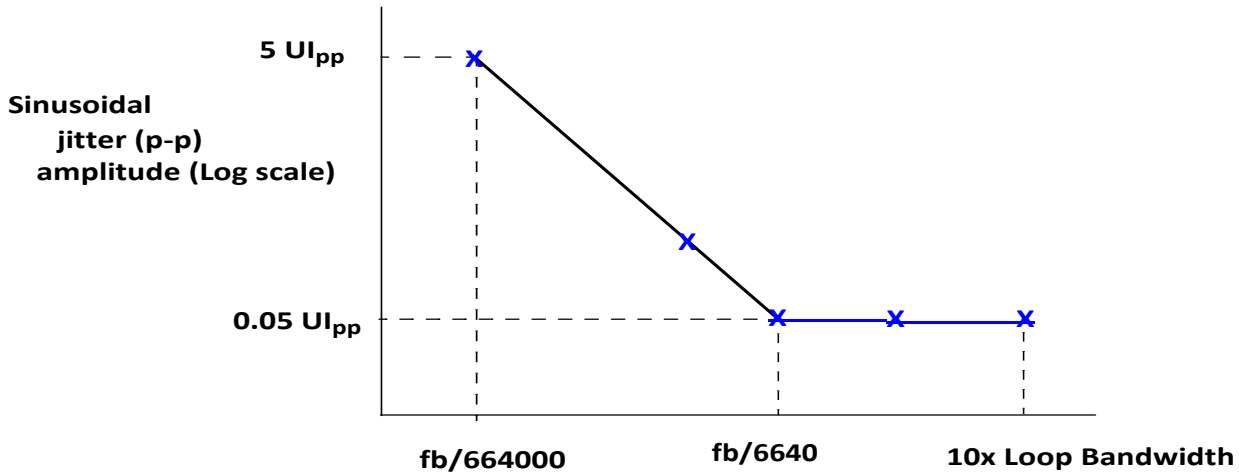

Figure 5-8: Receiver input sinusoidal jitter

Table 5-5: Sinusoidal jitter frequency for TP3 testing

Frequency Range	Sinusoidal jitter, peak-to-peak (UI)
$f < fb/664000$	Not specified
$fb/664000 < f \leq fb/6640$	$5 \cdot fb / (664000 \cdot f)$
$fb/6640 < f \leq 10$ times receiver loop bandwidth	0.05

## 6 FIBER OPTIC CABLING MODEL

The fiber optic cabling model is shown in Figure 6-1.

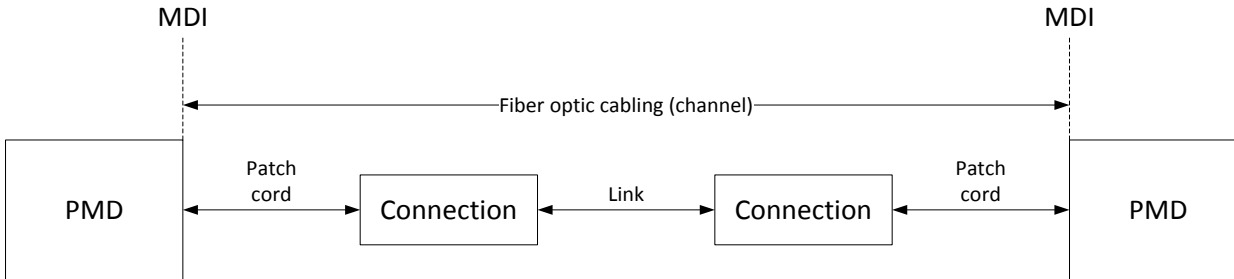

**Figure 6-1: Fiber optic cabling model**

The channel insertion loss is given in Table 6-1. A channel may contain additional connectors as long as the optical characteristics of the channel, such as attenuation, dispersion, reflections and polarization mode dispersion meet the specifications. Insertion loss measurements of installed fiber cables are made in accordance with IEC 61280-4-2 using the one-cord reference method. The fiber optic cabling model (channel) defined here is the same as a simplex fiber optic link segment. The term channel is used here for consistency with generic cabling standards.

**Table 6-1: Fiber optic cabling (channel) characteristics**

Description	400G-FR4-3-Open Eye Values	Unit
Operating distance (max)	3	km
Channel insertion loss <sup>a,b</sup> (max)	4	dB
Channel insertion loss (min)	0	dB
Positive dispersion <sup>b</sup> (max)	10.0	ps/nm
Negative dispersion <sup>b</sup> (min)	-17.8	ps/nm
DGD_max <sup>c</sup>	2.8	ps
Optical return loss (min)	25	dB

<sup>a</sup>These channel loss values include cable, connectors and splices.  
<sup>b</sup>Over the wavelength range 1264.5 to 1337.5 nm.  
<sup>c</sup>Differential Group Delay (DGD) is the time difference at reception between the fractions of a pulse that were transmitted in the two principal states of polarization of an optical signal. DGD\_max is the maximum differential group delay that the system must tolerate.

## 7 CHARACTERISTICS OF THE FIBER OPTIC CABLING

The 400G-FR4-3-Open Eye fiber optic cabling shall meet the specifications defined in Table 6-1. The fiber optic cabling consists of one or more sections of fiber optic cable and any intermediate connections required to connect sections together.

### 7.1 Optical Fiber Cable

The fiber optic cable requirements are satisfied by cables containing IEC 60793-2-50 type B1.1 (dispersion unshifted single-mode), type B1.3 (low water peak single-mode), or type B6\_a (bend insensitive) fibers and the requirements in Table 7-1 where they differ.

**Table 7-1: Optical fiber and cable characteristics**

Description	Value	Unit
Nominal fiber specification wavelength	1310	nm
Cabled optical fiber attenuation (max)	0.47 <sup>a</sup> or 0.5 <sup>b</sup>	dB/km
Zero dispersion wavelength ( $\lambda_0$ )	$1300 \leq \lambda_0 \leq 1324$	nm
Dispersion slope (max) ( $S_0$ )	0.092	ps/nm <sup>2</sup> km
<sup>a</sup> The 0.47 dB/km attenuation is provided for Outside Plant cable as defined in ANSI/TIA 568-C.3 and Appendix I or ITU-T G.695. <sup>b</sup> The 0.5 dB/km attenuation is provided for Outside Plant cable as defined in ANSI/TIA 568-C.3.		

### 7.2 Optical Fiber Connection

An optical fiber connection, as shown in Figure 6-1, consists of a mated pair of optical connectors.

#### 7.2.1 Connection insertion loss

The maximum link distance for 400GBASE-FR4 Open Eye is based on an allocation of 3 dB total connection and splice loss. Connections with different loss characteristics may be used provided the requirements of Table 6-1 are met.

#### 7.2.2 Maximum discrete reflectance

The maximum discrete reflectance shall be less than the value shown in Table 4-5.

### 7.3 Medium Dependent Interface (MDI) Requirement

The PMD is coupled to the fiber optic cabling at the MDI. The MDI is the interface between the PMD and the “fiber optic cabling” (as shown in Figure 6-1). Examples of an MDI include the following:

- a) Connectorized fiber pigtail
- b) PMD receptacle

When the MDI is a connector plug and receptacle connection, it shall meet the interface performance specifications of IEC 61753-1-1 and IEC 61753-021-2.

NOTE: Transmitter compliance testing is performed at TP2 i.e. after a 2 meter patch cord, not at the MDI.

## 8 400G-FR4-3-OPEN EYE MODULE COLOR CODING

Transceiver modules compliant to the 400G-FR4-3-Open Eye Specifications use a color code to indicate the application. This color code can be on a module bail latch, pull tab, or other visible feature of the module when installed in a system. The color code scheme is specified in Table 8-1.

**Table 8-1: 400G-FR4-3-Open Eye Module Color Coding**

<b>Color Code</b>	<b>Application</b>
TBD	400G-FR4-3-Open Eye